

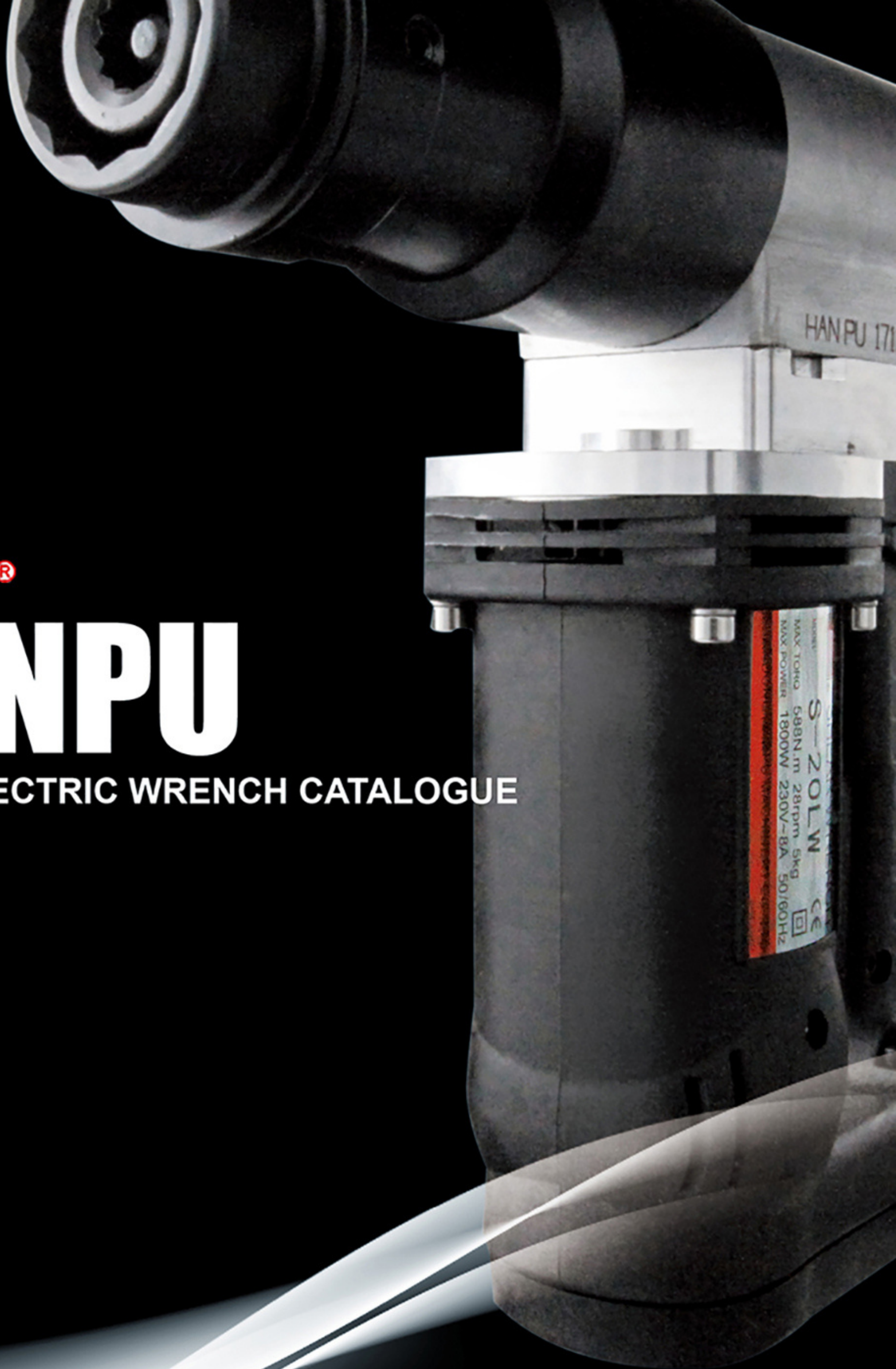

# HANPU

HANPU ELECTRIC WRENCH CATALOGUE

>> > >>>



# ELECTRIC SHEAR WRENCH



**CHARACTERISTICS**

Small size, light weight in the same level shear wrench.

Adapt well to narrow space and easy to operate.

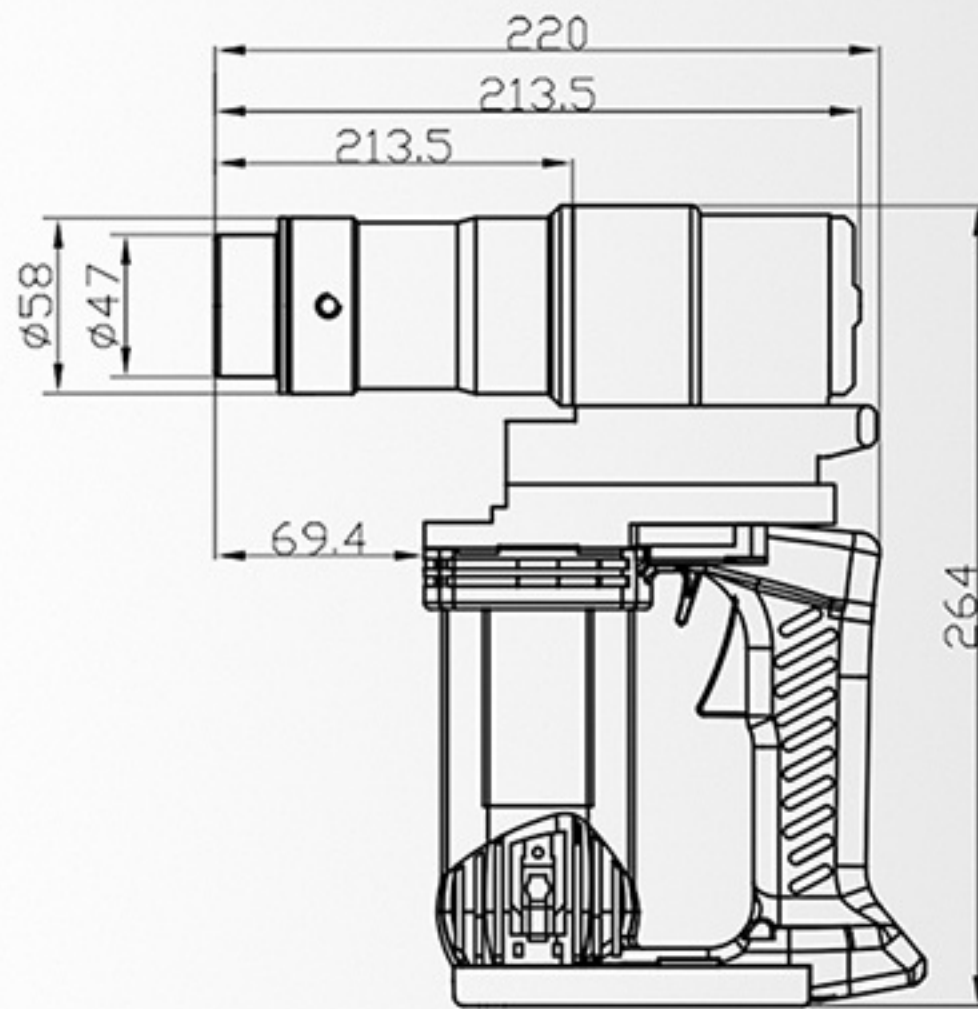
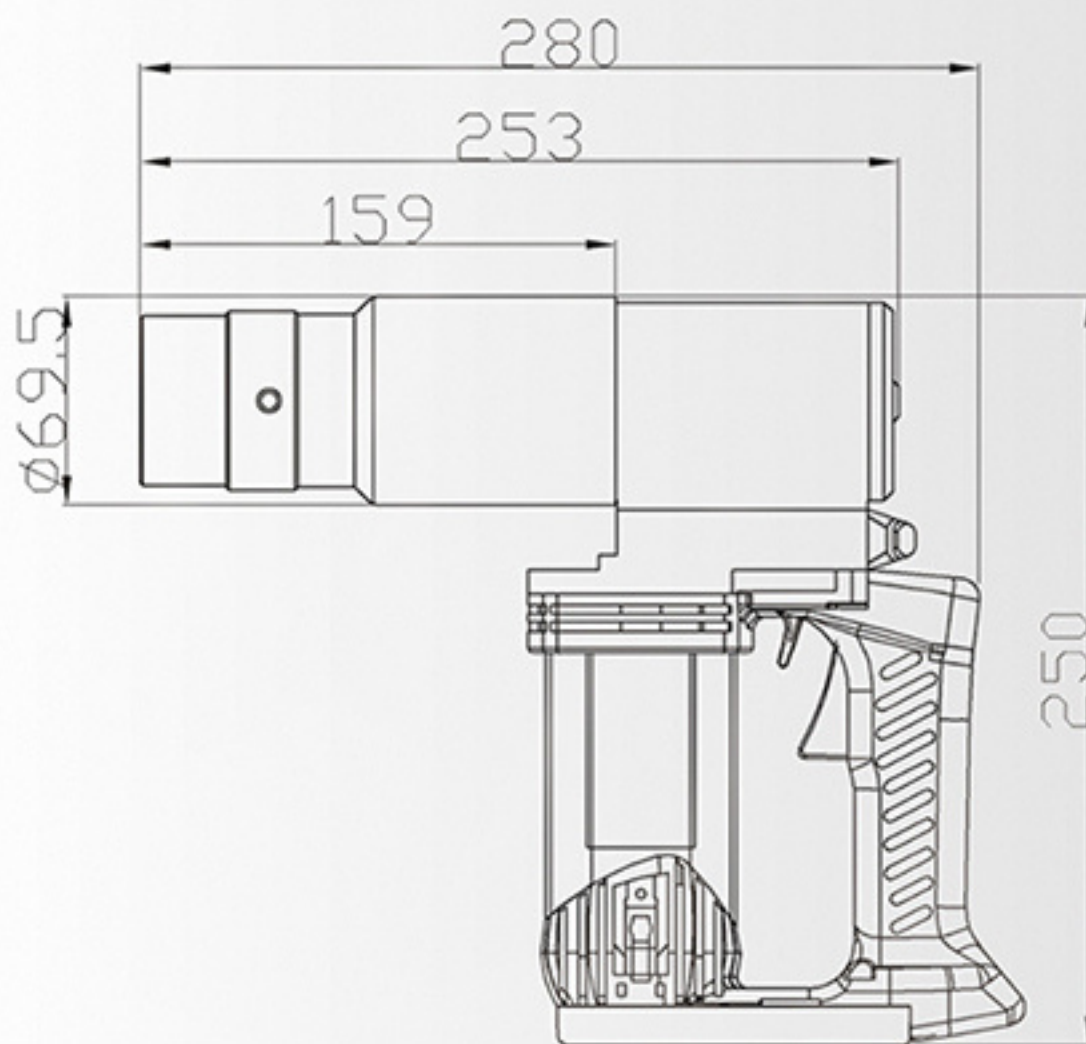
ELECTRIC SHEAR WRENCH-LW SERIES **S-20LW**ELECTRIC SHEAR WRENCH-LW SERIES **S-24LW**

MODEL	FREQ	VOLTAGE	MAX CURRENT	MAX POWER CONSUMPTION	MAX TORQUE	RO SPEED (min <sup>-1</sup> )	WEIGHT (MAIN BODY)	PROTECT CLASS	ADAPTABLE BOLTS DIA		
									S-10T	A325	A490
S-20LW	50-60Hz	230V 115V	8A 16A	1800W	640N.m	28rpm	4.9KG	Double Insulation	M12	1/2"	1/2"
									M16	5/8"	5/8"
									M20	3/4"	3/4"
S-24LW	50-60Hz	230V 115V	8A 16A	1800W	1200N.m	15rpm	5.5KG	Double Insulation	M16	5/8"	5/8"
									M20	3/4"	3/4"
									M22	7/8"	7/8"
									M24	1"	7/8"

2 sockets provided for free per Shear Wrench.



# ELECTRIC SHEAR WRENCH-LP SERIES

## CHARACTERISTICS

Light weight, smallest volume on same level shear wrench.

High strength, can tight higher strength bolt, like A490.

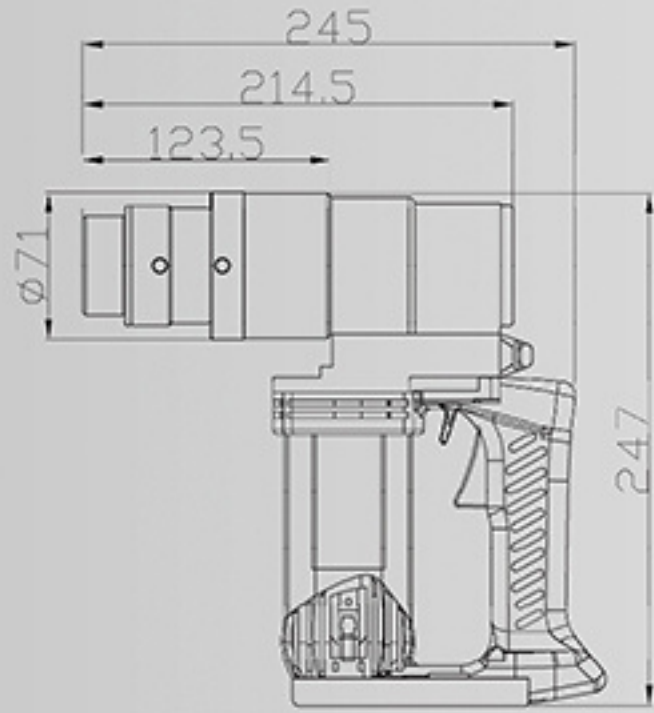

ELECTRIC SHEAR WRENCH -LP SERIES **S-22LP**

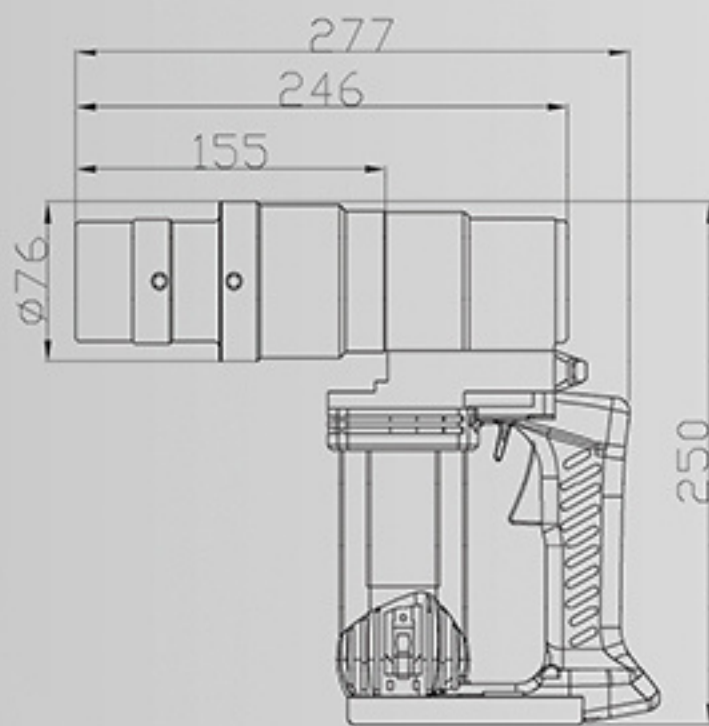

ELECTRIC SHEAR WRENCH -LP SERIES **S-24LP**

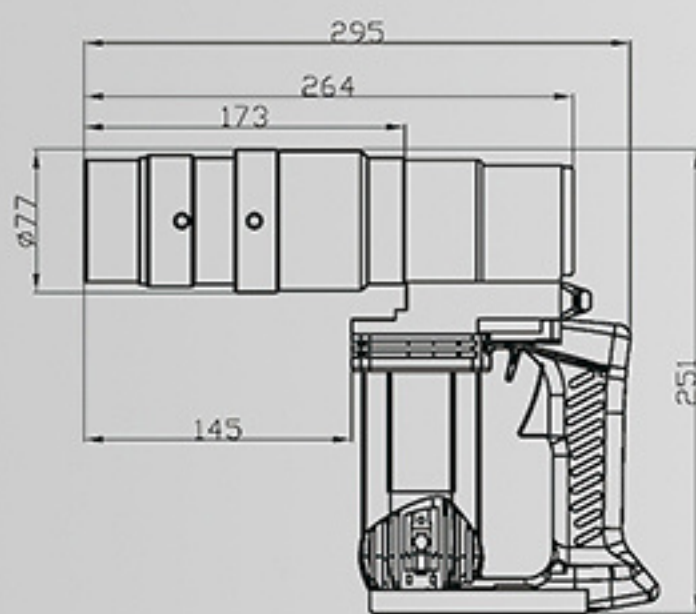

ELECTRIC SHEAR WRENCH -LP SERIES **S-27LP**

MODEL	FREQ	VOLTAGE	MAX CURRENT	MAX POWER CONSUMPTION	MAX TORQUE	RO SPEED (min-1)	WEIGHT (MAN BODY)	PROTECT CLASS	ADAPTABLE BOLTS DIA		
									S-10T	A325	A490
S-22LP	50-60Hz	230V 115V	8A 16A	1800W	900N.m	20rpm	5KG	Double Insulation	M16	5/8"	5/8"
									M20	3/4"	3/4"
									M22	7/8"	7/8"
S-24LP	50-60Hz	230V 115V	8A 16A	1800W	1200N.m	9rpm	5.5KG	Double Insulation	M16	5/8"	5/8"
									M20	3/4"	3/4"
									M22	7/8"	7/8"
									M24	1"	1"
S-27LP	50-60Hz	230V 115V	8A 16A	1800W	1800N.m	10rpm	6KG	Double Insulation	M16	5/8"	5/8"
									M20	3/4"	3/4"
									M22	7/8"	7/8"
									M24	1"	1"
									M27	1-1/8"	1-1/8"

Each wrench provide 2 sockets, one of them will be set on the wrench.

>> > >>> [www.hanpuindustrial.com](http://www.hanpuindustrial.com)



# ELECTRIC SHEAR WRENCH

## CHARACTERISTICS

Light weight, suitable for super high strength bolt tightening.  
High efficient, fast rotate speed, high torsion

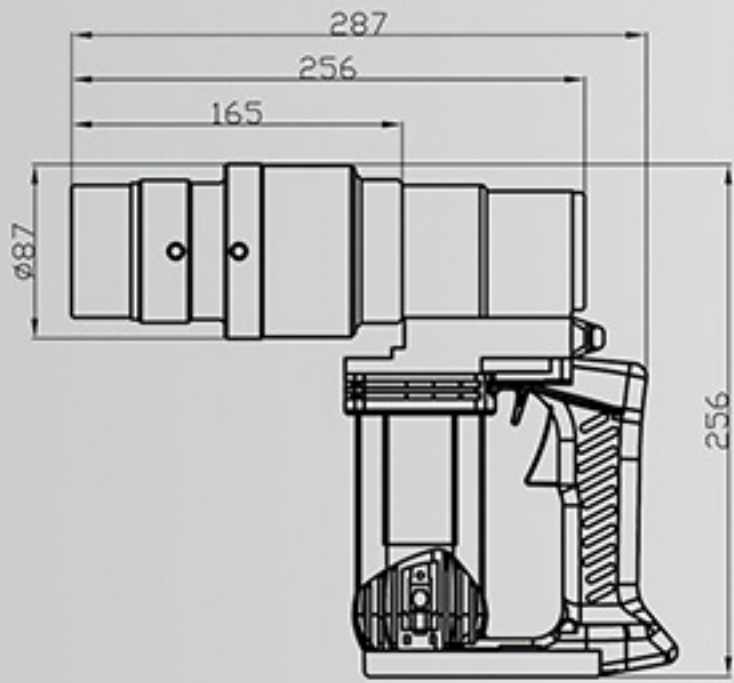

ELECTRIC SHEAR WRENCH -LP SERIES **S-30LP**

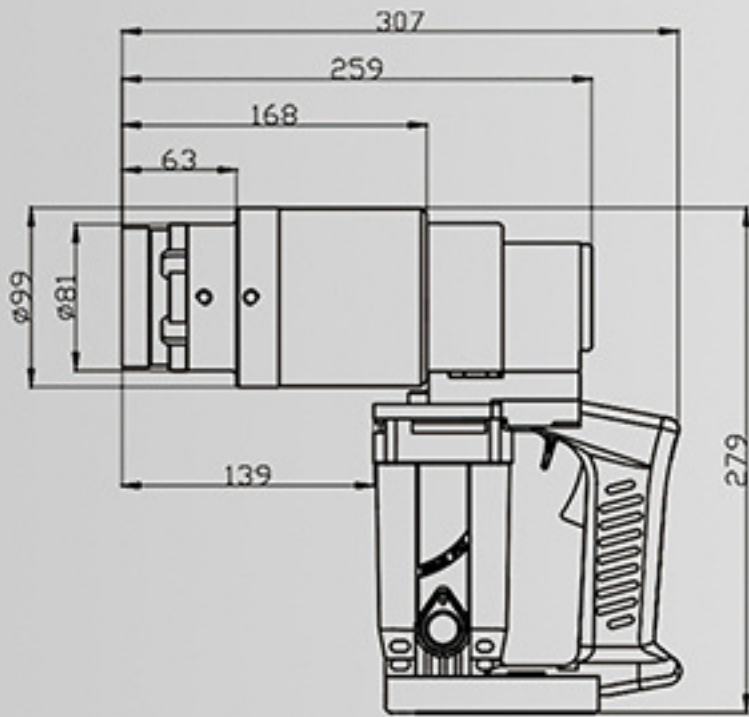

ELECTRIC SHEAR WRENCH **S-30G**

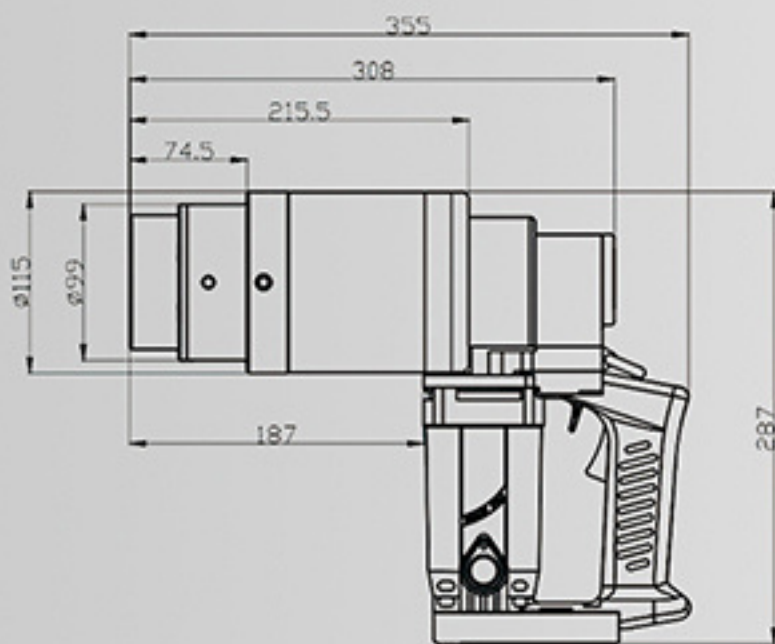

ELECTRIC SHEAR WRENCH **S-36G**

MODEL	FREQ	VOLTAGE	MAX CURRENT	MAX POWER CONSUMPTION	MAX TORQUE	RO SPEED (min-1)	WEIGHT (MAN BODY)	PROTECT CLASS	ADAPTABLE BOLTS DIA		
									S-10T	A325	A490
S-30LP	50-60Hz	230V 115V	8A 16A	1800W	2100N.m	6rpm	6.6KG	Double Insulation	M24 M27 M30	1" 1-1/8"	1" 1-1/8"
S-30G	50-60Hz	230V 115V	12A 24A	2800W	2500N.m	5rpm	8.7KG	Double Insulation	M24 M27 M30	1" 1-1/8" 1-1/4"	
S-36G	50-60Hz	230V 115V	12A 24A	2800W	3500N.m	2.5rpm	12.5KG	Double Insulation	M30 M33 M36	1-1/4" 1-3/8" 1-1/2"	

Each wrench provide 2 sockets, one of them will be set on the wrench.



# ELECTRIC SHEAR WRENCH INITIAL TIGHTENING

## CHARACTERISTICS

Used for pre tightening the high strength TC bolts.  
Precision control of initial tightening torque, light weight.

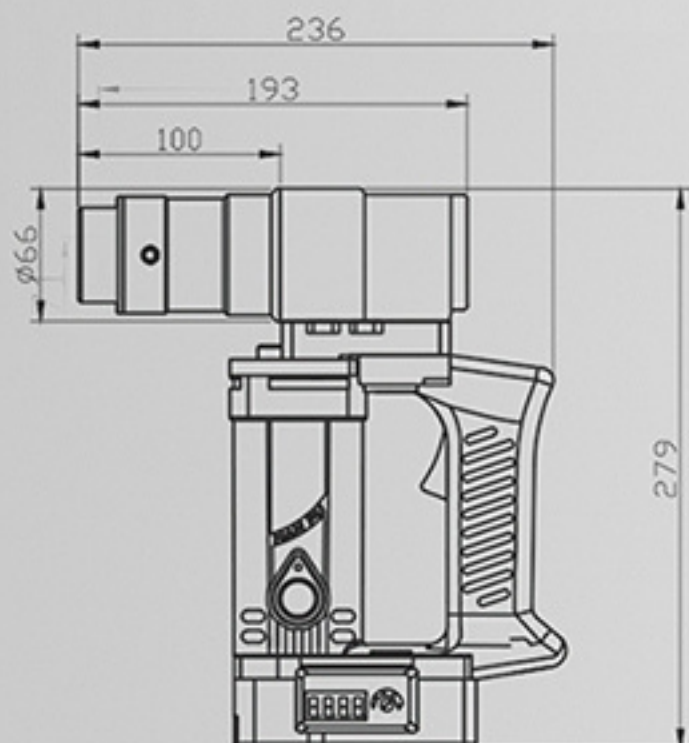

INITIAL TIGHTENING ELECTRIC SHEAR WRENCH **SSN-3T**

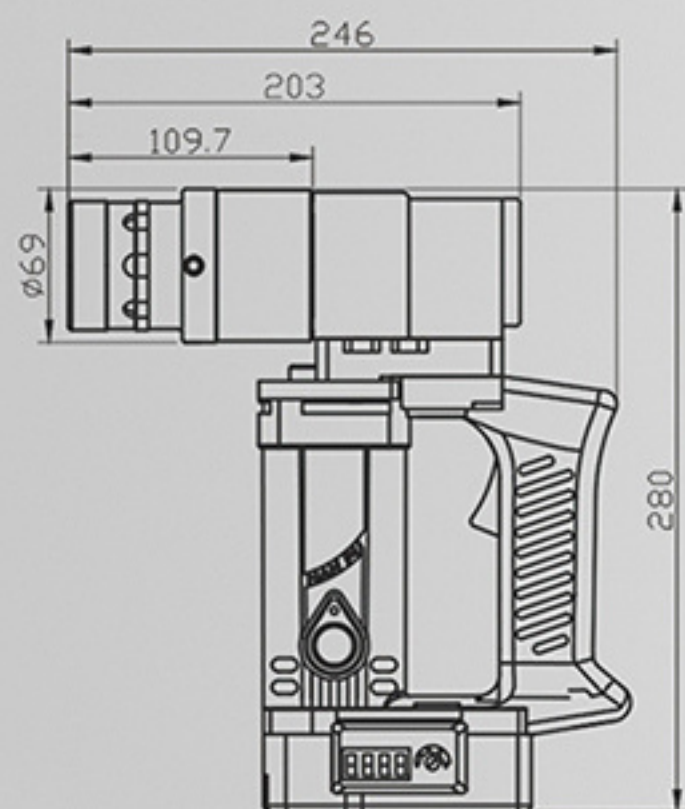

INITIAL TIGHTENING ELECTRIC SHEAR WRENCH **SSN-5T**

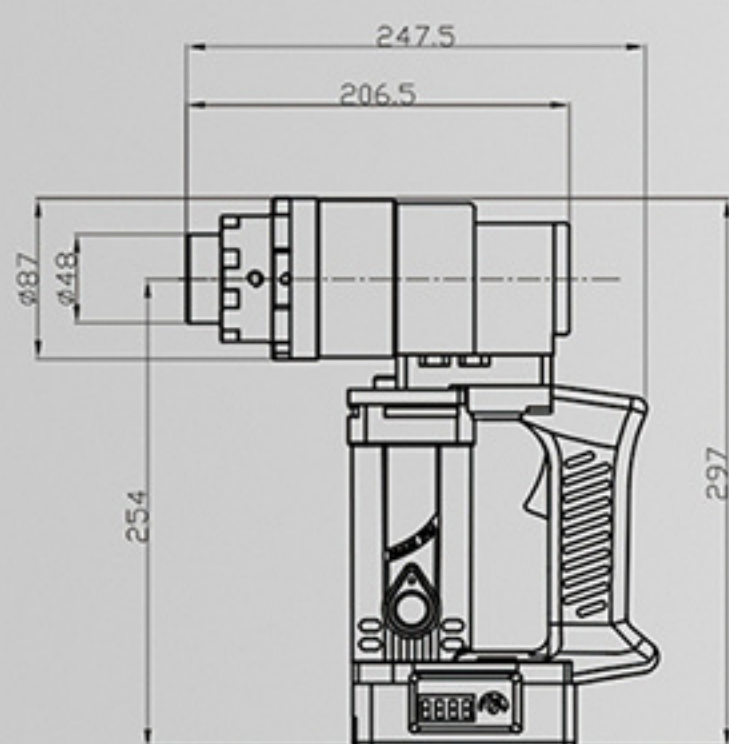

INITIAL TIGHTENING ELECTRIC SHEAR WRENCH **SHN-9T**

MODEL	FREQ	VOLTAGE	MAX CURRENT	TORQUE RANGE	MAX POWER CONSUMPTION	RO SPEED (min-1)	WEIGHT (MAIN BODY)	PROTECT CLASS	ADAPTABLE BOLTS DIA	
									S-10T	A325
SSN-3T	50-60Hz	230V 115V	7A 14A	100-300N.m	1650W	22rpm	4.5KG	Double Insulation	M16 M20	5/8" 3/4"
SSN-5T	50-60Hz	230V 115V	7A 14A	200-500N.m	1650W	16rpm	4.8KG	Double Insulation	M20 M22 M24	3/4" 7/8" 1"
SHN-9T	50-60Hz	230V 115V	7A 14A	500-1200N.m	1650W	12rpm	5.9KG	Double Insulation	M27 M30	1-1/8" 1-1/4"

2 sockets provided for free per Shear Wrench.

>> > >>> [www.hanpuindustrial.com](http://www.hanpuindustrial.com)

## CHARACTERISTICS

One tool with dual functions, both pre tightening and final tightening.

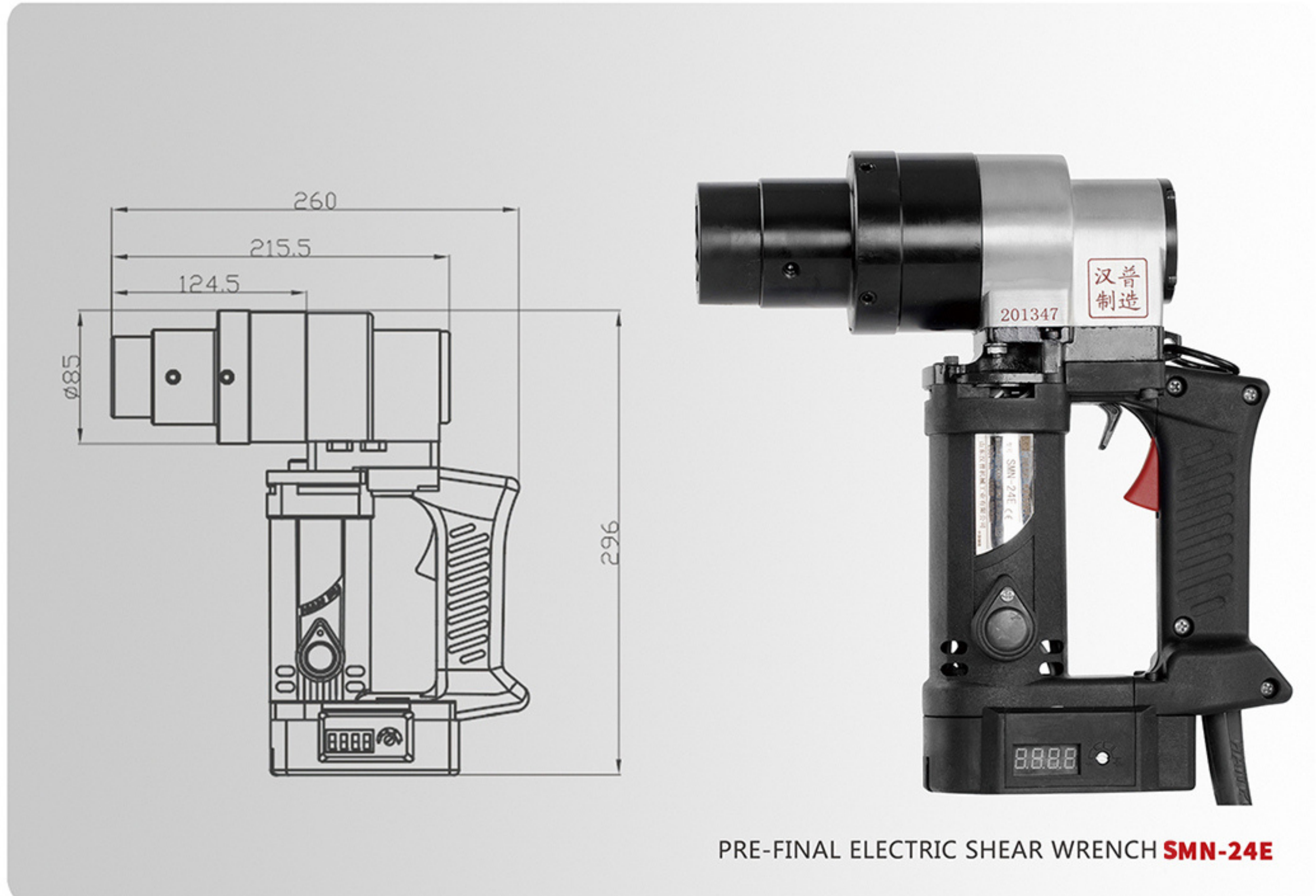

PRE-FINAL ELECTRIC SHEAR WRENCH **SMN-24E**

MODEL		SMN-24E
FREQ		50-60Hz
VOLTAGE		230V/115V
MAX CURRENT		7A/14A
TORQUE RANGE		300-900N.m
MAX POWER CONSUMPTION		1650W
RO SPEED (min-1)		10rpm
WEIGHT (MAIN BODY)		6KG
PROTECT CLASS		Double Insulation
ADAPTABLE BOLTS DIA	S-10T	M22 M24
	A325	7/8" 1"

2 sockets provided for free per Shear Wrench.



# INDEXABLE ELECTRIC SHEAR WRENCH

## CHARACTERISTICS

The mechanical part can be rotated 0-360 degrees, adapt to narrow space and different angles.

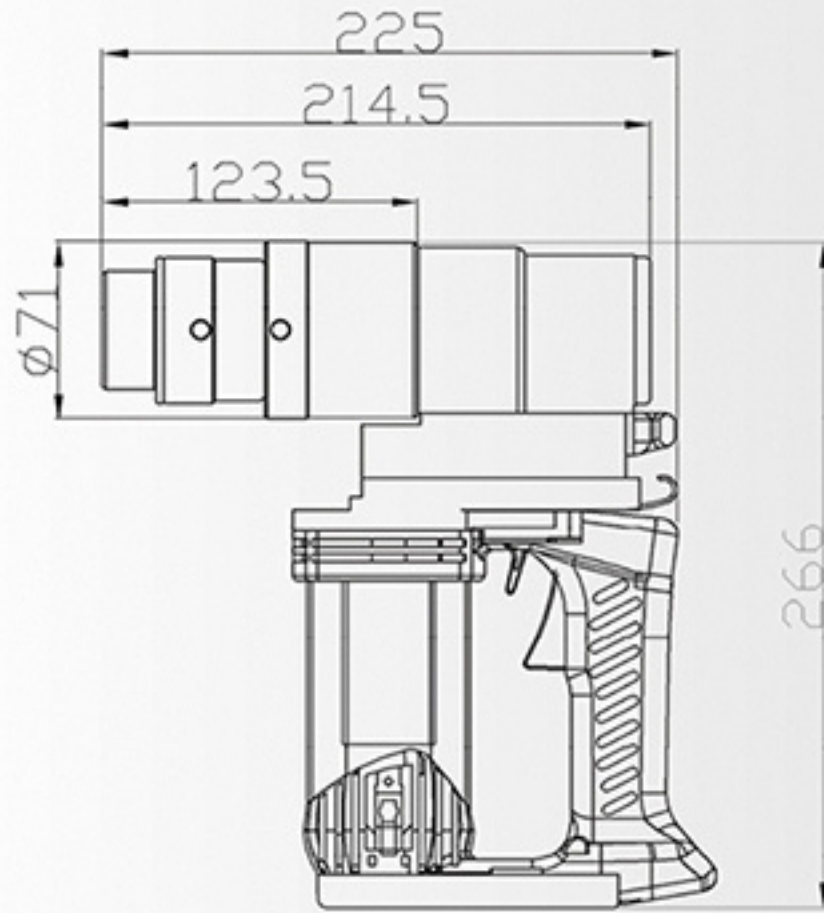

INDEXABLE ELECTRIC SHEAR WRENCH **SR-22LP**

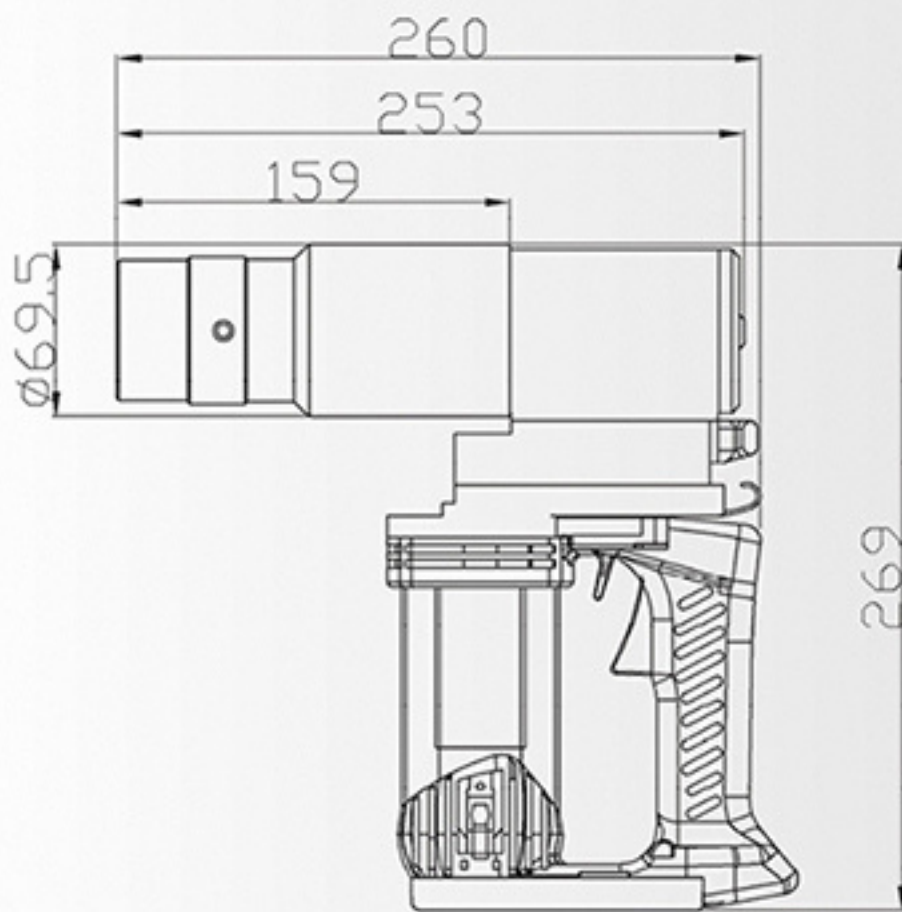

INDEXABLE ELECTRIC SHEAR WRENCH **SR-24LW**

## ROTATE ANGLES



**0/360°**



**90°**



**180°**



**270°**

MODEL	FREQ	VOLTAGE	MAX CURRENT	MAX POWER CONSUMPTION	MAX TORQUE	RO SPEED (min-1)	WEIGHT (MAIN BODY)	PROTECT CLASS	ADAPTABLE BOLTS DIA	
									S-10T	A325
SR-22LP	50-60Hz	230V 115V	8A 16A	1800W	900N.m	20rpm	5.6KG	Double Insulation	M16 M20 M22	5/8" 3/4" 7/8"
SR-24LW	50-60Hz	230V 115V	8A 16A	1800W	1200N.m	15rpm	6.1KG	Double Insulation	M16 M20 M22 M24	5/8" 3/4" 7/8" 1"

2 sockets provided for free per Shear Wrench.

>> > >>> [www.hanpuindustrial.com](http://www.hanpuindustrial.com)



## CHARACTERISTICS

Special corner design, perfectly adapt to narrow space.

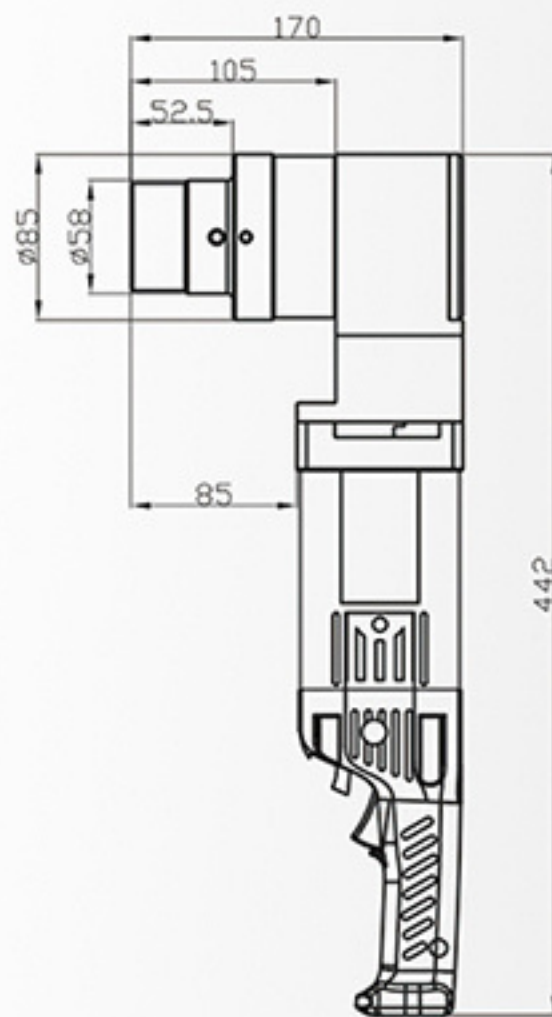

CORNER TYPE ELECTRIC SHEAR WRENCH **SC-24B**

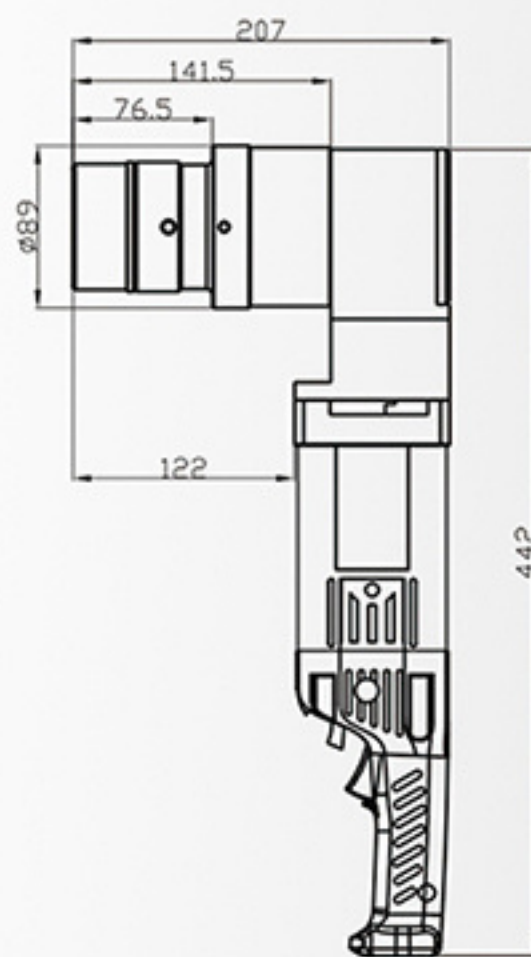

CORNER TYPE ELECTRIC SHEAR WRENCH **SC-30B**

MODEL		SC-24B	SC-30B
VOLTAGE		230V/115V	230V/115V
MAX CURRENT		10A/20A	10A/20A
MAX POWER CONSUMPTION		2200W	2200W
FREQ		50-60Hz	50-60Hz
MAX TORQUE		900N.m	2100N.m
RO SPEED (min-1)		12rpm	6rpm
WEIGHT (MAIN BODY)		6KG	7KG
ADAPTABLE BOLTS DIA	S-10T	M16 M20 M22 M24	M16 M20 M22 M24 M27 M30
	A325	5/8" 3/4" 7/8" 1"	5/8" 3/4" 7/8" 1" 1-1/8"

2 sockets provided for free per Shear Wrench.

# ELECTRIC TORQUE WRENCH

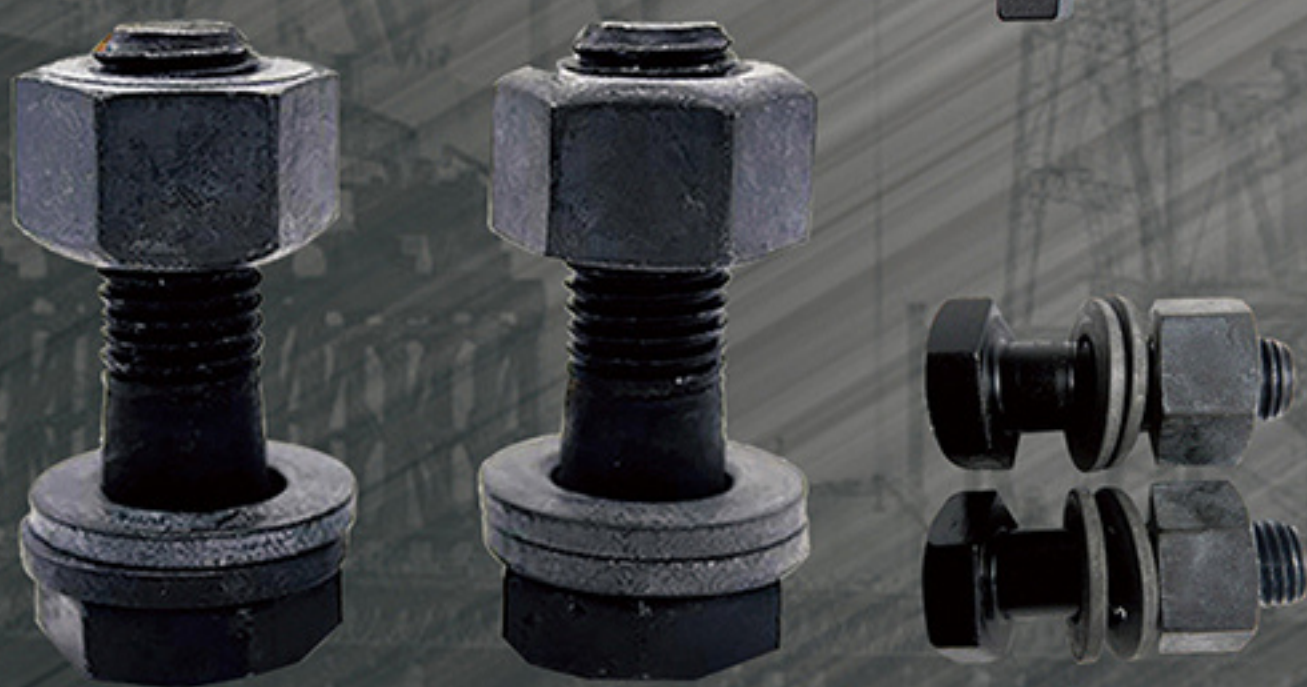



# ELECTRIC TORQUE WRENCH Y SERIES

## CHARACTERISTICS

Small volume, light weight, easy to operate.  
Adopt the digital controller, high precision.

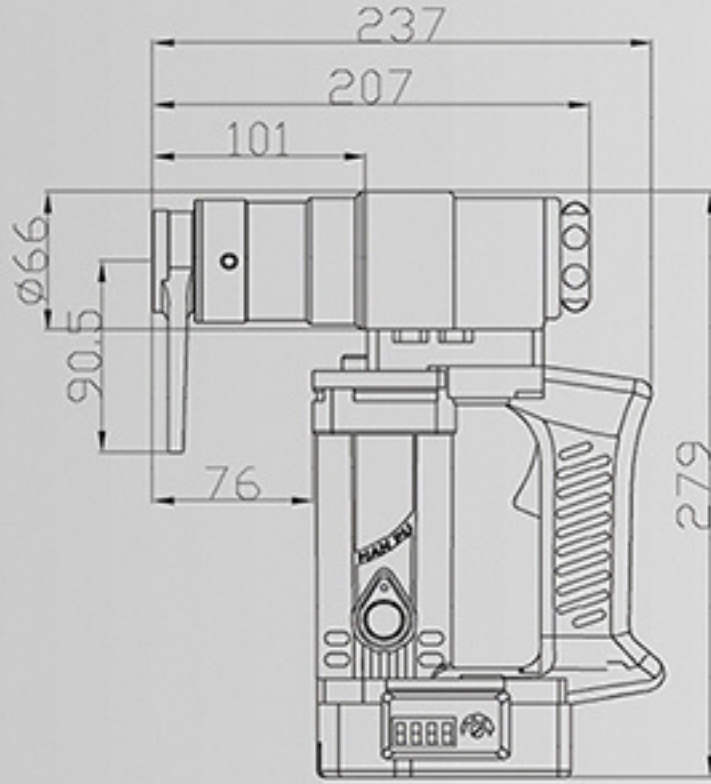

ELECTRIC TORQUE WRENCH Y SERIES **TN-3B**

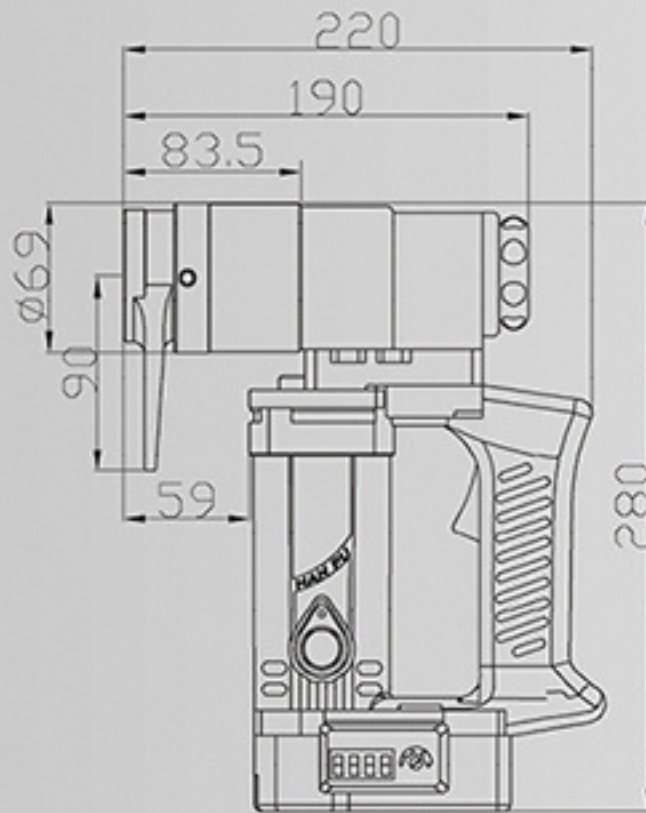

ELECTRIC TORQUE WRENCH Y SERIES **TN-5B**

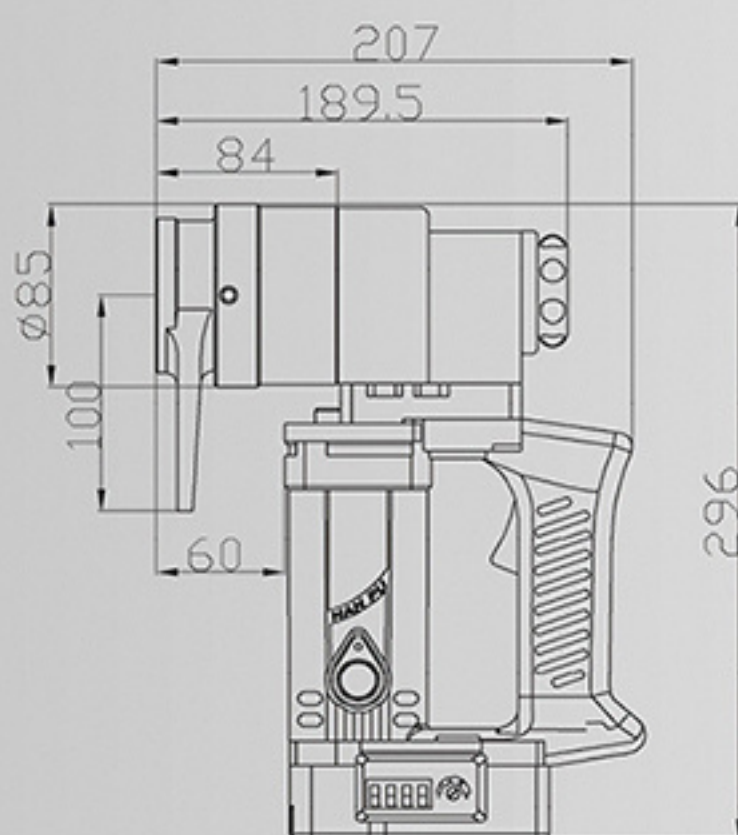

ELECTRIC TORQUE WRENCH Y SERIES **TN-9B**

MODEL	FREQ	VOLTAGE	MAX CURRENT	MAX POWER CONSUMPTION	TORQUE RANGE	RO SPEED (min-1)	WEIGHT (MAIN BODY)	PROTECT CLASS	ADAPTABLE BOLTS DIA		
									S-10T	A325	A490
TN-3B	50-60Hz	230V 115V	6A 12A	1300W	100-300N.m	24rpm	4.4KG	Double Insulation	M12 M16	1/2" 5/8"	1/2"
TN-5B	50-60Hz	230V 115V	7A 14A	1650W	200-500N.m	15.5rpm	4.5KG	Double Insulation	M16 M20	5/8" 3/4"	5/8"
TN-9B	50-60Hz	230V 115V	7A 14A	1650W	400-900N.m	9.5rpm	5.3KG	Double Insulation	M20 M22 M24	3/4" 7/8" 1"	3/4" 7/8"

1 socket provided for free per TN series Torque Wrench.



# ELECTRIC TORQUE WRENCH Y SERIES

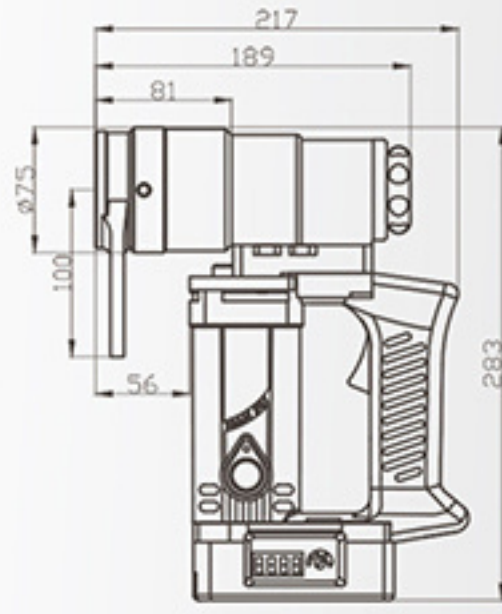
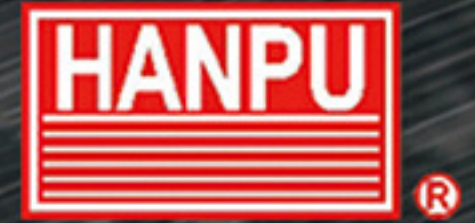

ELECTRIC TORQUE WRENCH Y SERIES **TN-7LP**

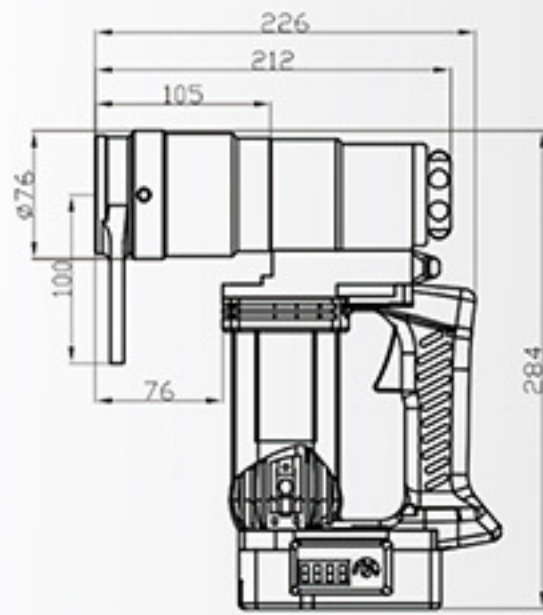

ELECTRIC TORQUE WRENCH Y SERIES **TN-12LP**

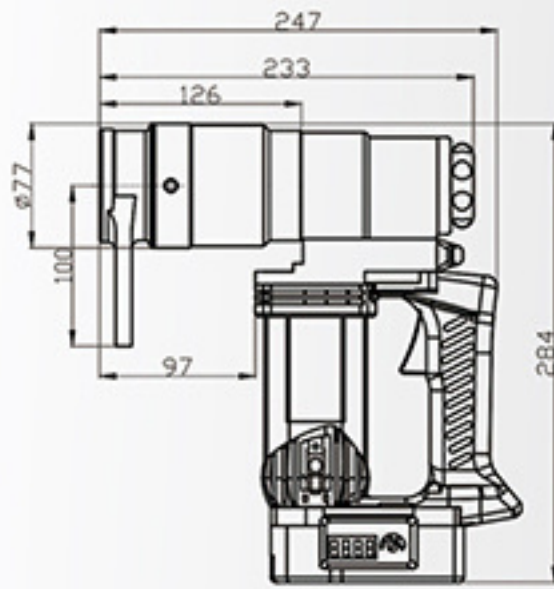

ELECTRIC TORQUE WRENCH Y SERIES **TN-18LP**

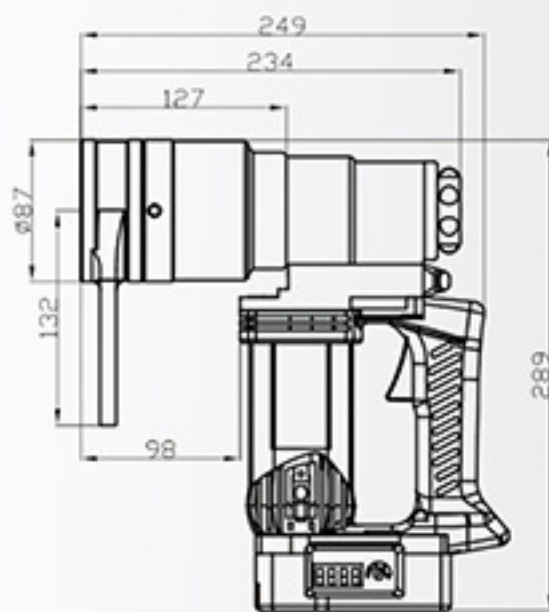

ELECTRIC TORQUE WRENCH Y SERIES **TN-21LP**

MODEL	FREQ	VOLTAGE	MAX CURRENT	MAX POWER CONSUMPTION	TORQUE RANGE	RO SPEED (min-1)	WEIGHT (MAIN BODY)	PROTECT CLASS	ADAPTABLE BOLTS DIA		
									S-10T	A325	A490
TN-7LP	50-60Hz	230V 115V	7A 14A	1650W	350- 700N.m	15rpm	4.7KG	Double Insulation	M20 M22	3/4" 7/8"	3/4"
TN-12LP	50-60Hz	230V 115V	8A 16A	1800W	500- 1200N.m	9rpm	5.5KG	Double Insulation	M22 M24	7/8" 1"	7/8" 1"
TN-18LP	50-60Hz	230V 115V	8A 16A	1800W	500- 1800N.m	10rpm	5.5KG	Double Insulation	M22 M24 M27	7/8" 1" 1-1/8"	7/8" 1" 1-1/8"
TN-21LP	50-60Hz	230V 115V	8A 16A	1800W	900- 2100N.m	6rpm	6.6KG	Double Insulation	M27 M30	1-1/8" 1-1/4"	1-1/8" 1-1/4"

1 socket provided for free per TN series torque wrench.



# ELECTRIC TORQUE WRENCH Y SERIES

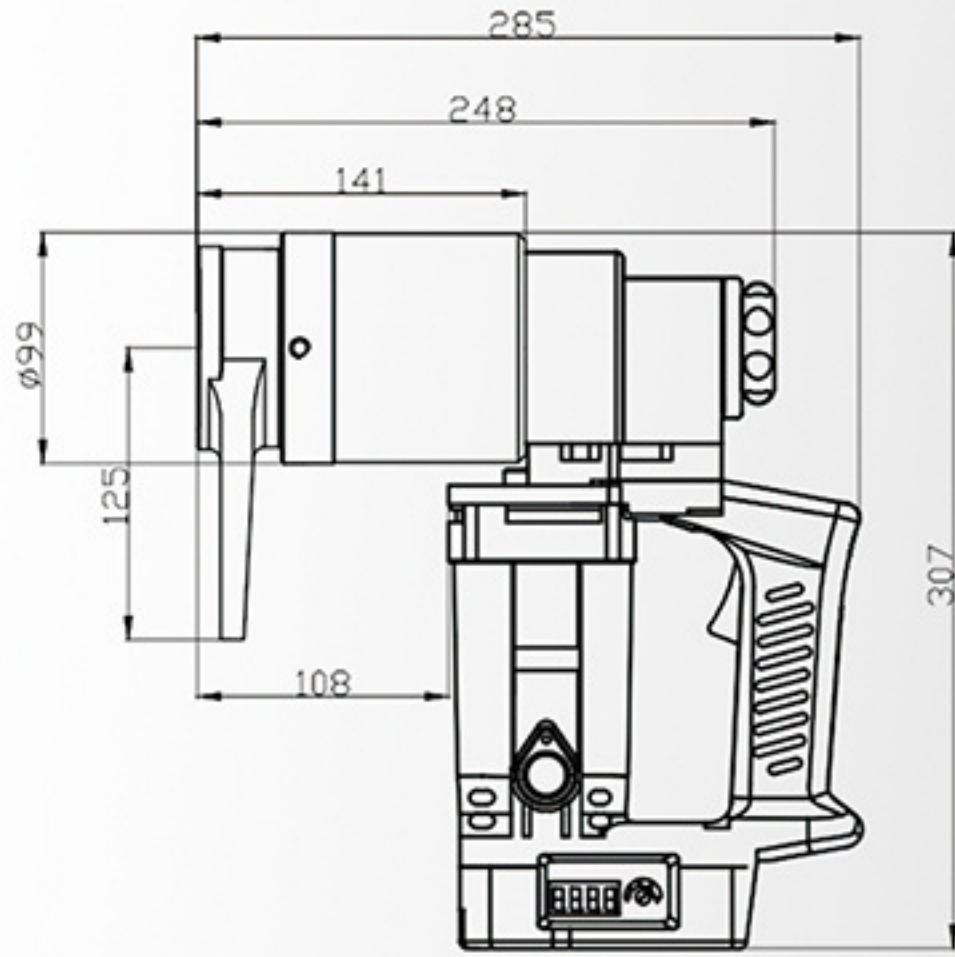

ELECTRIC TORQUE WRENCH Y SERIES **TN-25G**

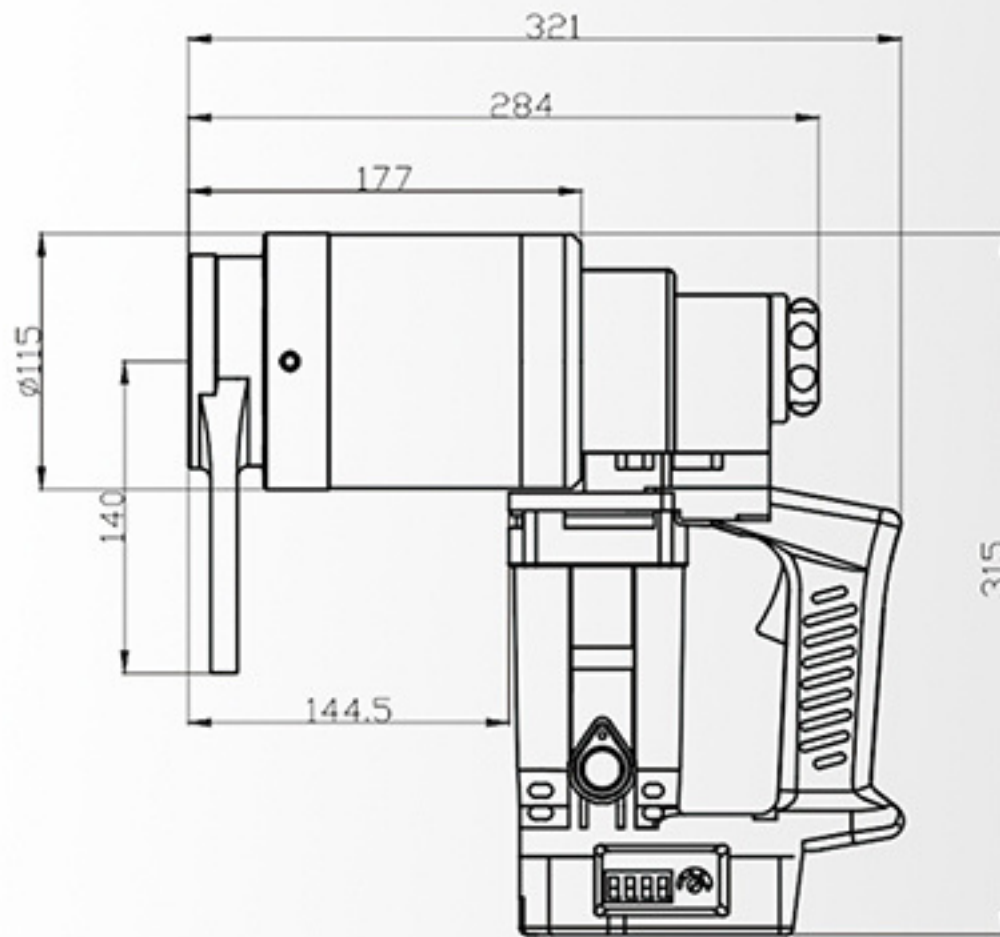

ELECTRIC TORQUE WRENCH Y SERIES **TN-35G**

MODEL	FREQ	VOLTAGE	MAX CURRENT	MAX POWER CONSUMPTION	TORQUE RANGE	RO SPEED	WEIGHT	PROTECT CLASS	ADAPTABLE BOLTS DIA		
									S-10T	A325	A490
TN-25G	50-60Hz	230V 115V	12A 24A	2800W	1000-2500N.m	5rpm	8.5KG	DOUBLE INSULATION	M27 M30 M33	1-1/8" 1-1/4" 1-3/8"	1-1/8" 1-1/4"
TN-35G	50-60Hz	230V 115V	12A 24A	2800W	1700-3500N.m	2.5rpm	12KG	DOUBLE INSULATION	M30 M33 M36	1-1/4" 1-3/8" 1-1/2"	1-1/4" 1-3/8"

1 socket provided for free per TN series torque wrench.

## CHARACTERISTICS

Small volume, light weight, easy to operate.  
Adopt the digital controller, high precision.

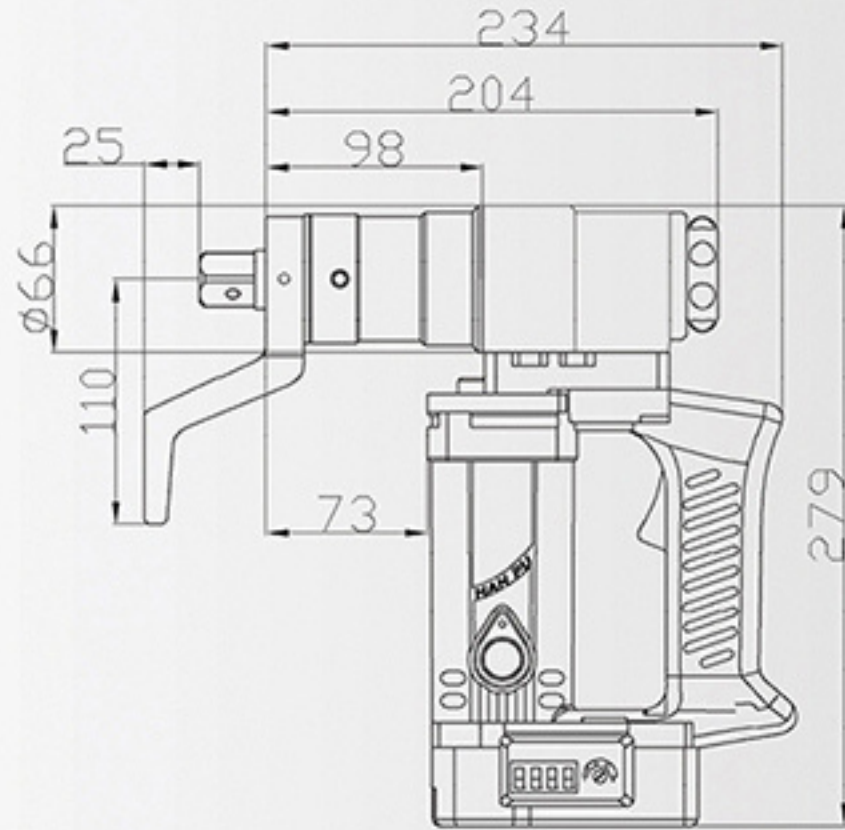

ELECTRIC TORQUE WRENCH L SERIES **TL-3B**

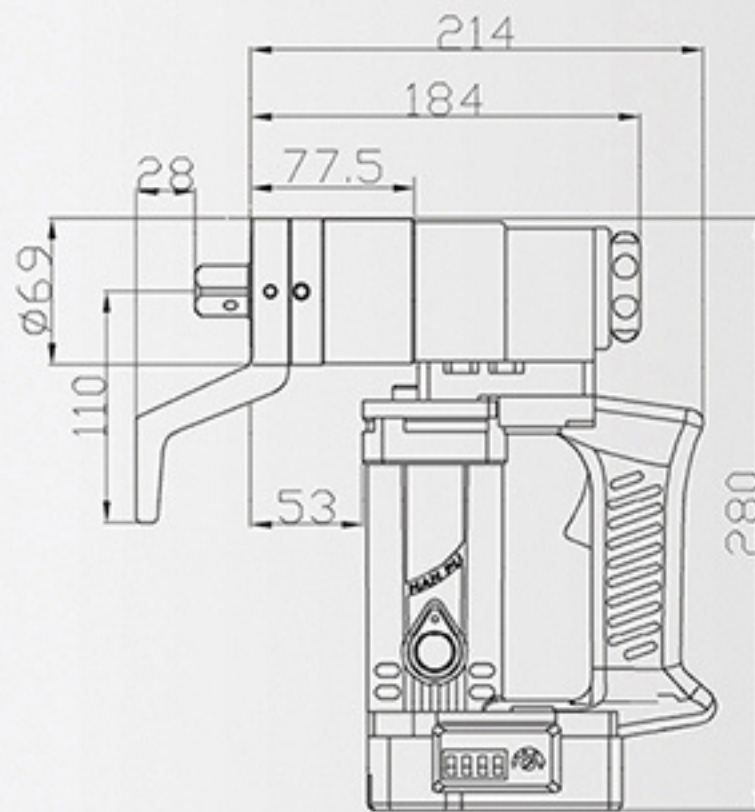

ELECTRIC TORQUE WRENCH L SERIES **TL-5B**

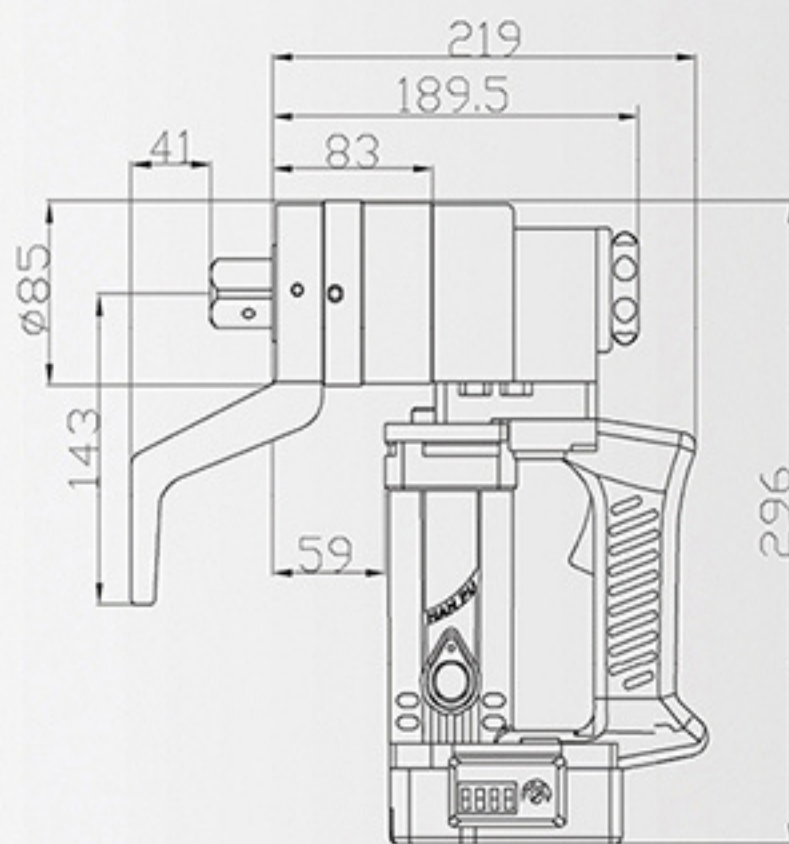

ELECTRIC TORQUE WRENCH L SERIES **TL-9B**

MODEL	FREQ	VOLTAGE	MAX CURRENT	MAX POWRE CONSUMPTION	TORQUE RANGE	RO SPEED (MIN-1)	WEIGHT (MAIN BODY)	SQUARE DRIVE	PROTECT CLASS	ADAPTABLE BOLTS DIA		
										S-10T	A325	A490
TL-3B	50-60Hz	230V 115V	6A 12A	1300W	100-300N.m	24rpm	4.4KG	19×19mm (3/4"×3/4")	Double insulation	M12 M16	1/2" 5/8"	1/2"
TL-5B	50-60Hz	230V 115V	7A 14A	1650W	200-500N.m	15.5rpm	4.5KG	19×19mm (3/4"×3/4")	Double insulation	M16 M20	5/8" 3/4"	5/8"
TL-9B	50-60Hz	230V 115V	7A 14A	1650W	400-900N.m	9.5rpm	5.3KG	25.4×25.4mm (1"×1")	Double insulation	M20 M22 M24	3/4" 7/8" 1"	3/4" 7/8"

No socket provided for free for TL series Torque Wrenches.

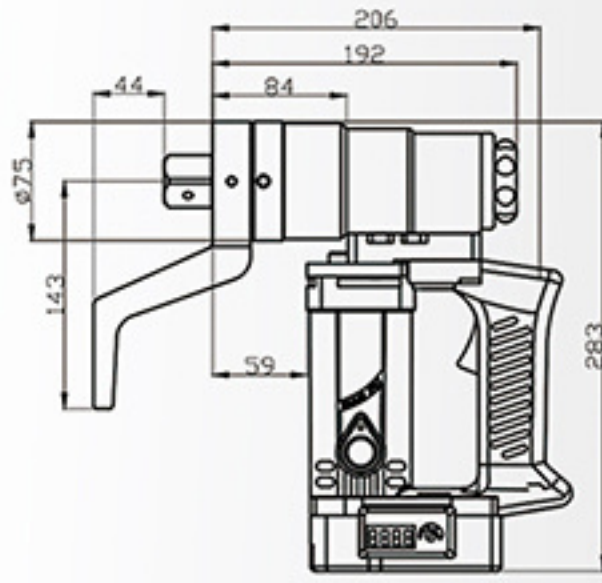

ELECTRIC TORQUE WRENCH L SERIES **TL-7LP**

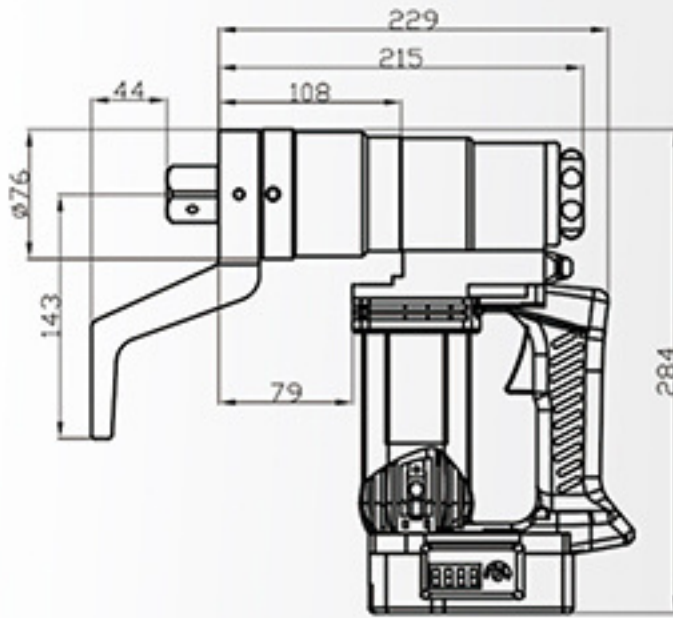

ELECTRIC TORQUE WRENCH L SERIES **TL-12LP**

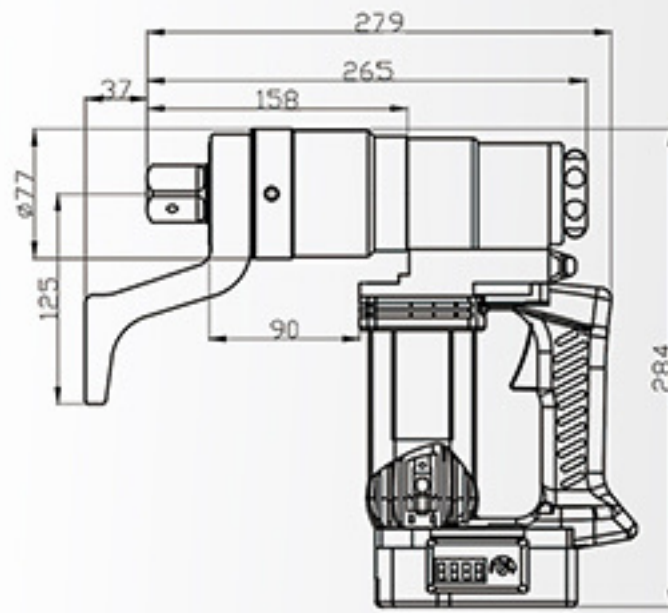

ELECTRIC TORQUE WRENCH L SERIES **TL-18LP**

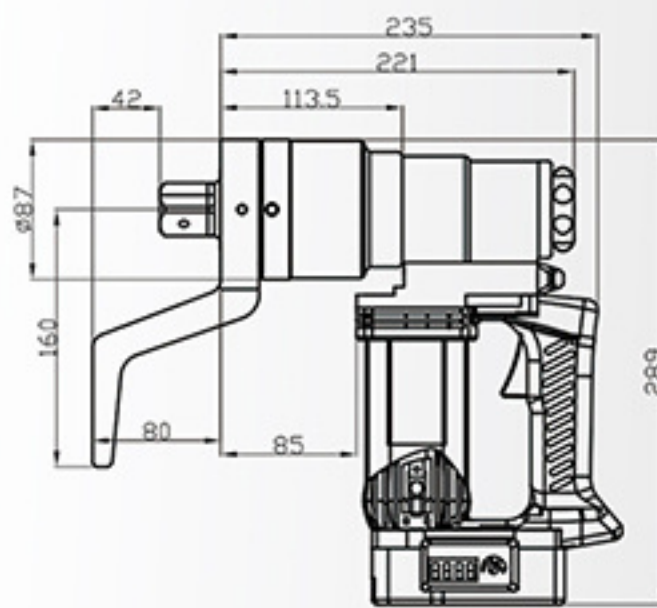

ELECTRIC TORQUE WRENCH L SERIES **TL-21LP**

MODEL	FREQ	VOLTAGE	MAX CURRENT	MAX POWER CONSUMPTION	TORQUE RANGE	RO SPEED (min-1)	WEIGHT (MAIN BODY)	SQUARE DRIVE	PROTECT CLASS	ADAPTABLE BOLTS DIA		
										S-10T	A325	A490
TL-7LP	50-60Hz	230V 115V	7A 14A	1650W	350- 700N.m	15rpm	4.7KG	25.4mm x 25.4mm (1" x 1")	Double Insulation	M20 M22	3/4" 7/8"	3/4"
TL-12LP	50-60Hz	230V 115V	8A 16A	1800W	500- 1200N.m	9rpm	5.5KG	25.4mm x 25.4mm (1" x 1")	Double Insulation	M22 M24	7/8" 1"	7/8" 1"
TL-18LP	50-60Hz	230V 115V	8A 16A	1800W	500- 1800N.m	10rpm	5.5KG	25.4mm x 25.4mm (1" x 1")	Double Insulation	M22 M24 M27 M30	7/8" 1" 1-1/8" 1-1/4"	7/8" 1" 1-1/8" 1-1/4"
TL-21LP	50-60Hz	230V 115V	8A 16A	1800W	900- 2100N.m	6rpm	6.6KG	25.4mm x 25.4mm (1" x 1")	Double Insulation	M27 M30	1-1/8" 1-1/4"	1-1/8" 1-1/4"

No socket provided for free for TL series Torque Wrenches.

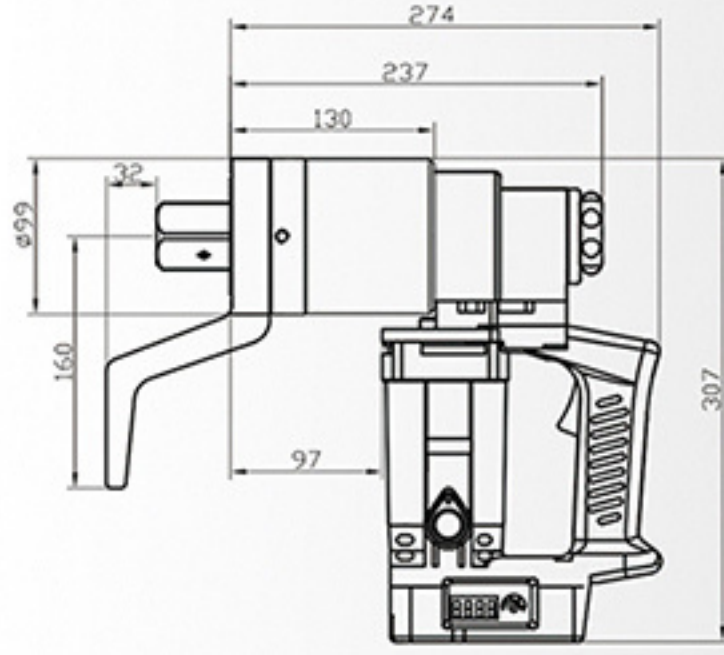

ELECTRIC TORQUE WRENCH L SERIES **TL-25G**

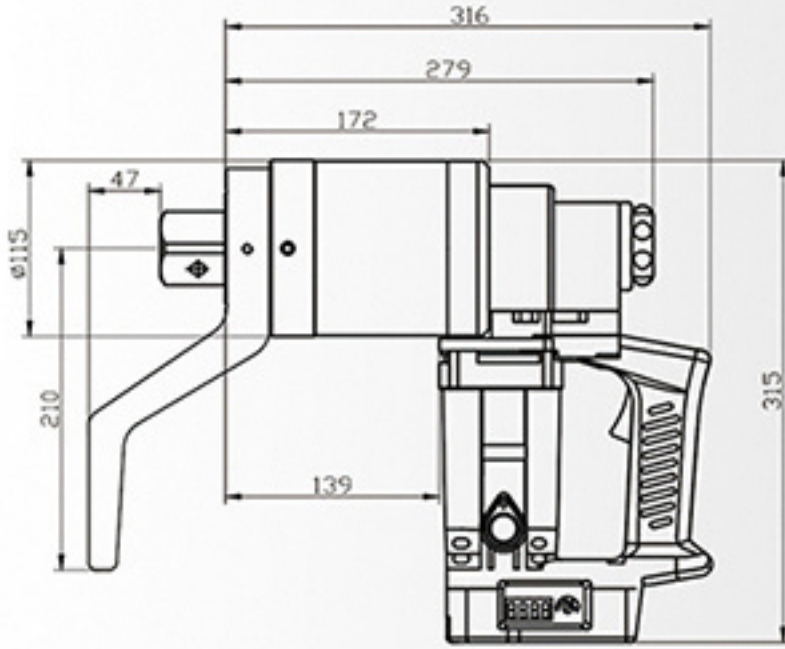

ELECTRIC TORQUE WRENCH L SERIES **TL-35G**

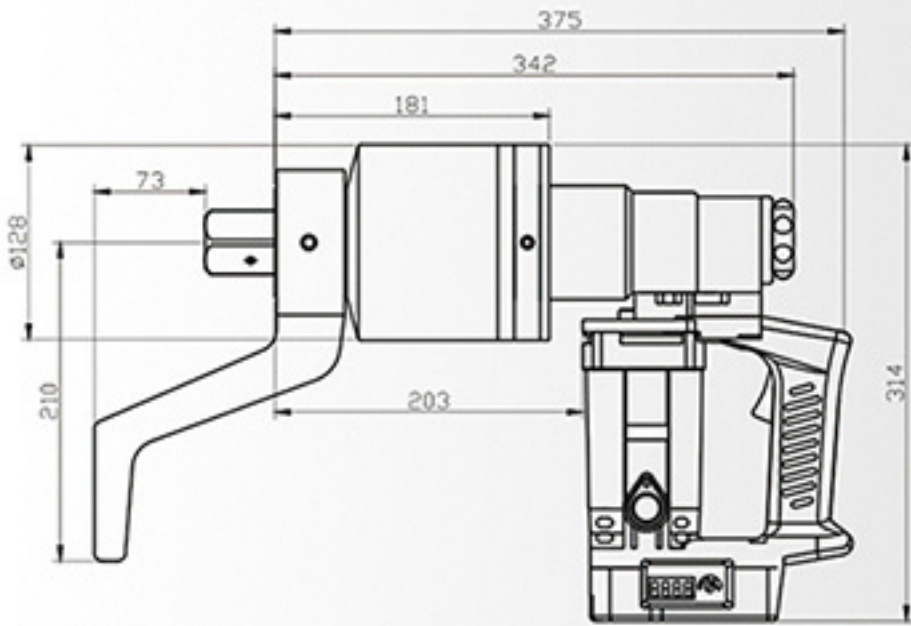

ELECTRIC TORQUE WRENCH L SERIES **TL-60G**

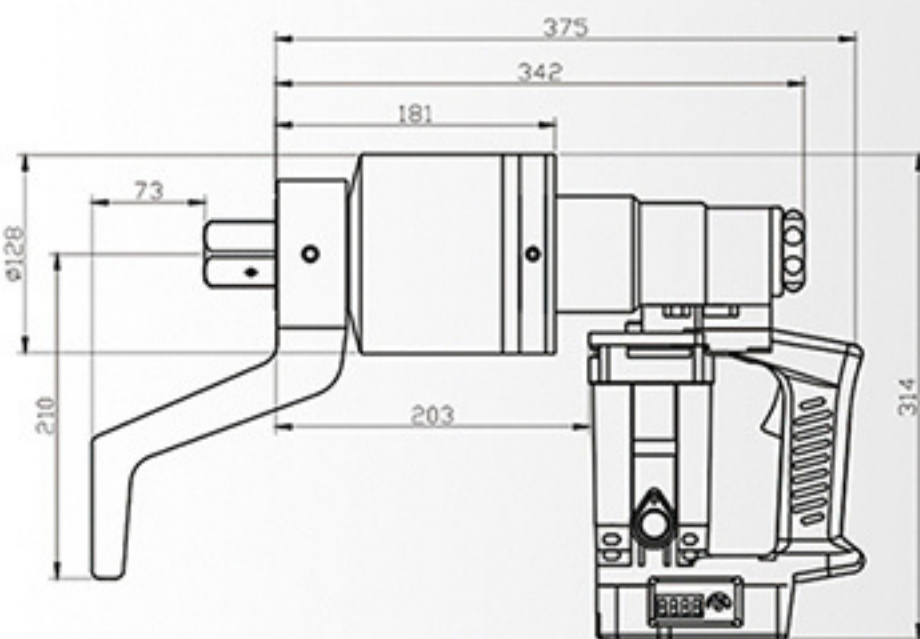

ELECTRIC TORQUE WRENCH L SERIES **TL-100G**

MODEL	FREQ	VOLTAGE	MAX CURRENT	MAX POWER CONSUMPTION	TORQUE RANGE	RO SPEED (min-1)	WEIGHT (MAIN BODY)	SQUARE DRIVE	PROTECT CLASS	ADAPTABLE BOLTS DIA		
										S-10T	A325	A490
TL-25G	50-60Hz	230V 115V	12A 24A	2800W	1000-2500N.m	5rpm	9.0KG	38mm x 38mm (1-1/2" x 1-1/2")	Double Insulation	M27 M30 M33	1-1/8" 1-1/4" 1-3/8"	1-1/8" 1-1/4"
TL-35G	50-60Hz	230V 115V	12A 24A	2800W	1700-3500N.m	2.5rpm	12KG	38mm x 38mm (1-1/2" x 1-1/2")	Double Insulation	M30 M33 M36	1-1/4" 1-3/8" 1-1/2"	1-1/4" 1-3/8"
TL-60G	50-60Hz	230V 115V	12A 24A	2800W	2000-6000N.m	0.6rpm	18.5KG	38mm x 38mm (1-1/2" x 1-1/2")	Double Insulation	M42 M45 M48	1-5/8" 1-3/4" 2"	1-5/8" 1-3/4"
TL-100G	50-60Hz	230V 115V	12A 24A	2800W	5000-10000N.m	0.3rpm	21KG	38mm x 38mm (1-1/2" x 1-1/2")	Double Insulation	M48 M52 M56	2" 2-1/8" 2-1/4"	2" 2-1/8"

No socket provided for free for TL series Torque Wrenches.



# ENGINEERING CASE

